

Prevents the passage of  
fire, smoke and sound



fireclamp®

## Fireclamp A Fire Resistant and Acoustic Sealant

**Fireclamp A is an easy-to-apply, highly flexible polymer emulsion sealant designed to provide fire protection wherever internal low movement and/or acoustic joints are required. When exposed to high temperature it swells to form a durable char that restricts the passage of smoke and fire for up to 4 hours.**

### Description

Fireclamp A is a halogen-free, polymer emulsion based sealant that swells when subjected to temperatures in excess of 125°C to form a durable char that restricts the passage of smoke and fire. It is easy to apply and is designed for internal use wherever low movement fire resistant and/or acoustic joints are required.

In addition, it has also been extensively fire tested to provide fire seals around a wide range of pipe and cable service penetrations through fire compartmenting floors and walls including 100mm thick flexible (plasterboard) partitions.

### Performance

Fireclamp A has been tested to the latest European requirements for applications in walls and floors. Testing to other national standards is also available.

- Fire classification to EN 13501-2 and CE Mark (ETA 18/0841 & 18/0842)
- Flexible Walls (stud partitions) or rigid walls (masonry, concrete) of 100mm minimum thickness

- Rigid (concrete) floors of 150mm minimum thickness
- Tested in conjunction with a wide range of common construction materials including masonry, steel, wood, bunched telecommunications cables, large power cables and steel and copper pipes
- +/- 12.5% movement capability (conforms to ISO 11600 F 12.5P)
- Mechanical and durability testing to ETAG 026-2; Z2 (0/+70°C) (internal use with temperature range of 0°C to +40°C and high humidity)
- High strength for loadbearing designs
- Mechanical and durability testing to ETAG 026-2; Y2 (-5/+70°C) (internal use with temperature range of -5°C to +70°C and high humidity) with no loss of compressive strength
- Sound insulation: RW up to 57dB (BS EN ISO 10140-2: 2010)
- VOC Emissions Classification: M1 (highest European classification)
- Third party product certification with UL International (Certificate # UL-EU-00717)
- Sound insulation: Rw up to 59dB (BS EN ISO 10140-2: 2010)
- Zero flame spread when tested to EN ISO 11923-2: 2010 giving Class E classification to EN 13501-1:2007 + A1
- VOC Emissions Classification: M1 (highest European classification)

### Other properties

- Colour: White (other colours available in minimum order quantities)
- Specific gravity: 1.60 - 1.64
- Skinning time: 15 to 60 minutes depending on conditions
- Cure time: 5 to 15 days for a 20 x 15mm bead
- Hardness (Shore A): 25 - 30
- Painting: Can be over painted with most paints once fully cured

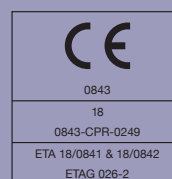

For fire performance tables  
see the next page

### Linear gaps in masonry/concrete walls of minimum thickness 200mm

Maximum gap size (mm)	Seal position	Minimum seal depth (mm)	Backing material	Minimum backing depth (mm)	Fire performance (mins)	
					Integrity (E)	Integrity & insulation (EI)
10	Either side	12	PE or stone mineral wool	N/A	240	240
10	Either side	10	PE or stone mineral wool	N/A	240	180
10	Both sides	10	Stone mineral wool*	25	240	240
20	Either side	22	PE or stone mineral wool	N/A	240	120
20	Either side	20	PE or stone mineral wool	N/A	240	90
30	Either side	25	PE or stone mineral wool	N/A	240	60
30	Both sides	20	Stone mineral wool*	25	240	240
30	Both sides	15	Stone mineral wool*	25	240	180

\*Nominal compressed density 90kg/m<sup>3</sup>.

### Linear gaps in masonry/concrete walls of minimum thickness 150mm

Maximum gap size (mm)	Seal position	Minimum seal depth (mm)	Backing material	Minimum backing depth (mm)	Fire performance (mins)	
					Integrity (E)	Integrity & insulation (EI)
20	Both sides	10	PE or stone mineral wool	N/A	240	180
25	Both sides	12.5	PE or stone mineral wool	N/A	240	180
30	Both sides	15	PE or stone mineral wool	N/A	240	180
35	Both sides	17.5	PE or stone mineral wool	N/A	240	180
40	Both sides	20	PE or stone mineral wool	N/A	240	180
50	Both sides	10	Fireclamp FP200 foam	130	240	240
100	Both sides	10	Stone mineral wool*	130	240	240

\*Nominal compressed density 90kg/m<sup>3</sup>.

### Linear gaps in masonry/concrete walls of minimum thickness 100mm

Maximum gap size (mm)	Seal position	Minimum seal depth (mm)	Backing material	Minimum backing depth (mm)	Fire performance (mins)	
					Integrity (E)	Integrity & insulation (EI)
30	Both sides	10	PE or stone mineral wool	N/A	180	60
30	Both sides	15	PE or stone mineral wool	N/A	240	120
40	Both sides	20	PE or stone mineral wool	N/A	240	120
50	Both sides	10	Fireclamp FP200 foam	80	240	120

Continues on the next page

**Linear gaps in partition to partition walls of minimum thickness 100mm or similar partition walls to masonry/concrete**

Maximum gap size (mm)	Seal position	Minimum seal depth (mm)	Backing material	Minimum backing depth (mm)	Fire performance (mins)	
					Integrity (E)	Integrity & insulation (EI)
25	Both sides	10	Stone mineral wool*	80	120	120

\*Nominal compressed density 90kg/m<sup>3</sup>.

**Linear gaps in partition to partition walls of minimum thickness 100mm to masonry/concrete**

Maximum gap size (mm)	Seal position	Minimum seal depth (mm)	Backing material	Minimum backing depth (mm)	Fire performance (mins)	
					Integrity (E)	Integrity & insulation (EI)
20	Both sides	10	Stone mineral wool*	15	120	120
20	Both sides	25	Steel stud	N/A	120	120

\*Nominal compressed density 90kg/m<sup>3</sup>.

**Linear gaps against steel in masonry/concrete walls of minimum thickness 150mm**

Maximum gap size (mm)	Seal position	Minimum seal depth (mm)	Backing material	Minimum backing depth (mm)	Fire performance (mins)	
					Integrity (E)	Integrity & insulation (EI)
30	Both sides	10	PE or stone mineral wool	N/A	240	90
50	Both sides	25	Stone mineral wool**	50	240	240

\*\*Nominal compressed density 110kg/m<sup>3</sup>.

**Linear gaps against steel in masonry/concrete walls of minimum thickness 100mm**

Maximum gap size (mm)	Seal position	Minimum seal depth (mm)	Backing material	Minimum backing depth (mm)	Fire performance (mins)	
					Integrity (E)	Integrity & insulation (EI)
30	Both sides	10	PE or stone mineral wool	N/A	240	60
50	Both sides	25	Stone mineral wool**	50	240	120

\*\*Nominal compressed density 110kg/m<sup>3</sup>.

**Linear gaps against timber in masonry/concrete walls of minimum thickness 150mm**

Maximum gap size (mm)	Seal position	Minimum seal depth (mm)	Backing material	Minimum backing depth (mm)	Fire performance (mins)	
					Integrity (E)	Integrity & insulation (EI)
30	Both sides	15	PE or stone mineral wool	N/A	180	180
50	Both sides	25	Stone mineral wool**	50	120	120

\*\*Nominal compressed density 110kg/m<sup>3</sup>.

**Linear gaps against timber in masonry/concrete walls of minimum thickness 100mm**

Maximum gap size (mm)	Seal position	Minimum seal depth (mm)	Backing material	Minimum backing depth (mm)	Fire performance (mins)	
					Integrity (E)	Integrity & insulation (EI)
30	Both sides	20	PE or stone mineral wool	N/A	60	60
30	Both sides	15	Stone mineral wool**	70	120	120
50	Both sides	25	Stone mineral wool**	50	60	60

\*Nominal compressed density 90kg/m<sup>3</sup>. \*\*Nominal compressed density 110kg/m<sup>3</sup>.

**Linear gaps against timber in masonry/concrete walls of minimum thickness 92mm**

Maximum gap size (mm)	Seal position	Minimum seal depth (mm)	Backing material	Minimum backing depth (mm)	Fire performance (mins)	
					Integrity (E)	Integrity & insulation (EI)
20	Both sides	10	Fireclamp FP 200 expanding foam	72	120	120

**Linear gaps in concrete walls of minimum thickness 150mm**

Maximum gap size (mm)	Seal position	Minimum seal depth (mm)	Backing material	Minimum backing depth (mm)	Fire performance (mins)	
					Integrity (E)	Integrity & insulation (EI)
10	Non-fire side	10	PE or stone mineral wool	N/A	240	120
20	Non-fire side	10	PE or stone mineral wool	N/A	240	60
30	Non-fire side	20	PE or stone mineral wool	N/A	120	60
30	Non-fire side	10	Stone mineral wool*	25	240	180
30	Both sides	10	PE or stone mineral wool	N/A	240	180

\*Nominal compressed density 90kg/m<sup>3</sup>.

**Linear gaps against steel in floors of minimum thickness 150mm**

Maximum gap size (mm)	Seal position	Minimum seal depth (mm)	Backing material	Minimum backing depth (mm)	Fire performance (mins)	
					Integrity (E)	Integrity & insulation (EI)
230	Both sides	10	PE or stone mineral wool**	N/A	240	90

\*\*Nominal compressed density 110kg/m<sup>3</sup>.

**Linear gaps against timber in floors of minimum thickness 150mm**

Maximum gap size (mm)	Seal position	Minimum seal depth (mm)	Backing material	Minimum backing depth (mm)	Fire performance (mins)	
					Integrity (E)	Integrity & insulation (EI)
30	Both sides	10	PE or stone mineral wool	N/A	120	120
30	Both sides	15	Stone mineral wool*	120	180	180

\*Nominal compressed density 90kg/m<sup>3</sup>.

Continues on the next page

**Penetration seals in partitions or masonry/concrete walls of minimum thickness 100mm**

Max. opening size (mm)	Penetrating service	Seal position	Min. seal depth (mm)	Backing material	Min. backing depth (mm)	Fire performance (mins)	
						Integrity (E)	Integrity & insulation (EI)
400 x 400	Blank seal	Both sides	10	Stone mineral wool*	80	120	120
	Steel cable ladder/tray	Both sides	10	Stone mineral wool*	80	120	90
	HD604.5 cables up to 13mm dia., single/bunched	Both sides	10	Stone mineral wool*	80	120	60 (90)
	HD603.3 cables up to 14mm dia., single/bunched	Both sides	10	Stone mineral wool*	80	120	60 (90)
	HD22.4 cables up to 15mm dia., single/bunched	Both sides	10	Stone mineral wool*	80	120	45 (60)
	HD603.3 cables up to 21mm dia., single/bunched	Both sides	10	Stone mineral wool*	80	120	30 (60)
	HD604.5 cables up to 42mm dia., single/bunched	Both sides	10	Stone mineral wool*	80	120	60
	HD603.3 cables up to 42mm dia., single/bunched	Both sides	10	Stone mineral wool*	80	120	30 (45)
	HD603.3 cables up to 52mm dia., single/bunched	Both sides	10	Stone mineral wool*	80	120	30 (60)
	HD22.4 cables up to 61mm dia., single/bunched	Both sides	10	Stone mineral wool*	80	120	45 (60)
	Up to 19mm dia. copper/steel pipe + 25mm thick continuous mineral wool insulation	Both sides	10	Stone mineral wool*	80	120	120
	Up to 67mm dia. copper/steel pipe + 25mm thick continuous mineral wool insulation	Both sides	10	Stone mineral wool*	80	120	90

\*Nominal compressed density 90kg/m<sup>3</sup>.

**Penetration seals in partitions or masonry/concrete walls of minimum thickness 150mm**

Max. opening size (mm)	Penetrating service	Seal position	Min. seal depth (mm)	Backing material	Min. backing depth (mm)	Fire performance (mins)	
						Integrity (E)	Integrity & insulation (EI)
120 dia.	HD604.5 cables up to 42mm dia., single/bunched	Both sides	15	Stone mineral wool**	25	240	120
90 dia.	HD603.3 cables up to 42mm dia., single/bunched	Both sides	15	Stone mineral wool**	25	240	60
110 dia.	Telecoms cables up to 21mm dia., single/bunched	Both sides	12	Stone mineral wool**	25	60	60
400 x 400	Steel armored cables up to 30mm dia., single/bunched	Both sides	10	Stone mineral wool*	130	120	60
	Up to 35mm dia. copper/steel pipe	Both sides	10	Stone mineral wool*	25	90	-
	Up to 35mm dia. copper/steel pipe + 19mm thick interrupted nitrile rubber insulation	Both sides	10	Stone mineral wool*	130	90	90
	Up to 89mm dia. copper/steel pipe	Both sides	10	Stone mineral wool*	130	120	30
	Up to 89mm dia. copper/steel pipe + 19mm thick interrupted nitrile rubber insulation	Both sides	10	Stone mineral wool*	130	120	120

\*Nominal compressed density 90kg/m<sup>3</sup>. \*\*Nominal compressed density 110kg/m<sup>3</sup>.

Continues on the next page

**Penetration seals in concrete floors of minimum thickness 150mm**

Max. opening size (mm)	Penetrating service	Seal position	Min. seal depth (mm)	Backing material	Min. backing depth (mm)	Fire performance (mins)	
						Integrity (E)	Integrity & insulation (EI)
120 dia.	Telecoms cables up to 21mm dia., single/bunched	Both sides	12	Stone mineral wool**	25	240	90
	HD604.5 cables up to 42mm dia., single/bunched	Both sides	20	Stone mineral wool**	25	120	60
90 dia.	HD603.3 cables up to 42mm dia., single/bunched	Both sides	15	Stone mineral wool**	25	120	45
110 dia.	BS7671-6944XLH cables up to 14mm dia., single/bunched	Both sides	10	Stone mineral wool*	130	240	120
	BS7671-6944LSH cables up to 19mm dia., single/bunched	Both sides	10	Stone mineral wool*	130	240	90
	BS7671-6944XLH cables up to 25mm dia., single/bunched	Both sides	10	Stone mineral wool*	130	240	90
350 x 150	Up to 19mm dia. copper/steel pipe + 25mm thick continuous mineral wool insulation	Both sides	10	Stone mineral wool*	130	240	240
150 dia.	Up to 35mm dia. copper/steel pipe	Both sides	10	Stone mineral wool*	130	240	-
	Up to 35mm dia. copper/steel pipe + 19mm thick interrupted nitrile rubber insulation (500mm minimum)	Both sides	10	Stone mineral wool*	130	240	180
	Up to 35mm dia. copper/steel pipe + 40mm thick interrupted mineral wool insulation (500mm minimum)	Both sides	10	Stone mineral wool*	130	240	180
120 dia.	Up to 35mm dia. copper/steel pipe	Both sides	15	Stone mineral wool*	25	240	180
350 x 150	Up to 63mm dia. copper/steel pipe + 25mm thick continuous mineral wool insulation	Both sides	10	Stone mineral wool*	130	240	180
150 dia.	Up to 89mm dia. copper/steel pipe	Both sides	10	Stone mineral wool*	130	240	15
	Up to 35mm dia. copper/steel pipe + 25mm thick interrupted nitrile rubber insulation (500mm minimum)	Both sides	10	Stone mineral wool*	130	240	120
300 dia.	Up to 219mm dia. steel pipe	Both sides	20	Stone mineral wool*	25	180	120

\*Nominal compressed density 90kg/m<sup>3</sup>. \*\*Nominal compressed density 110kg/m<sup>3</sup>.

**Packaging schedule**

Item	Pack size (ml)	Items per box	Boxes per pallet		Items per pallet	
			Standard 4-way (1.2 x 1.0m)	Euro (1.2 x 0.8m)	Standard 4-way (1.2 x 1.0m)	Euro (1.2 x 0.8m)
Cartridge	310	25	64	48	1600	1200
Cartridge	310	12	132	100	1584	1200
Foil	600	12	78	72	936	864

**Supply, packaging and usage**

Firebreak A is normally supplied in 310ml cartridges or 600ml foil packs. It can also be supplied in 5, 10, 15 or 19 litre tubs to order.

The quantity of material required to seal a linear gap without allowance for wastage can be calculated using the following equations with all dimensions measured in cm:

Gap width x seal depth x gap length / 310  
= number of 310ml cartridges required

Gap width x seal depth x gap length / 600  
= number of 600ml foils required

*Note: Multiply by 2 where seal is to both faces of separating structure.*

**Continues on the next page**

### Linear gap installation

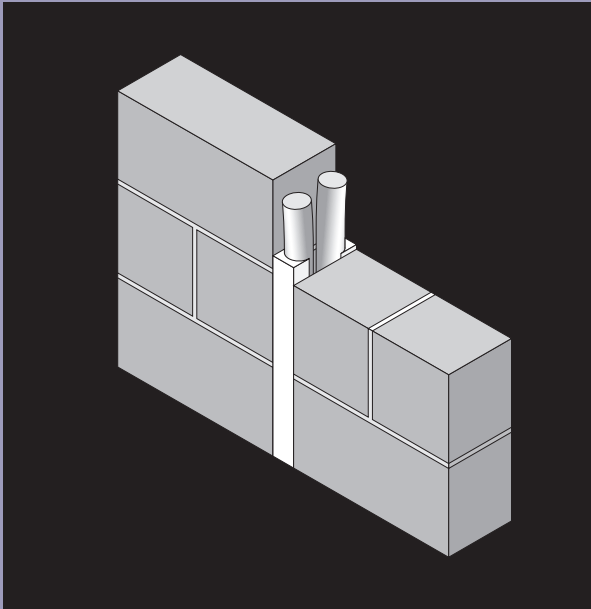

### Service penetration installation

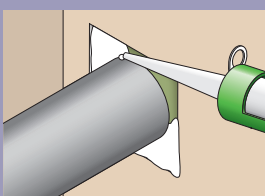
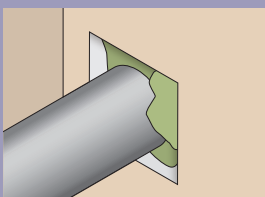
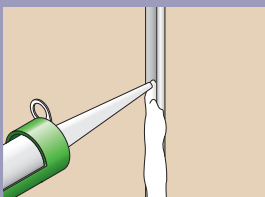
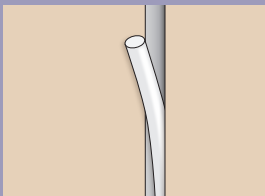
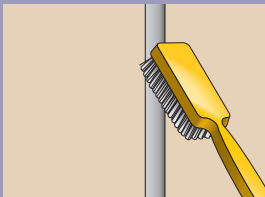
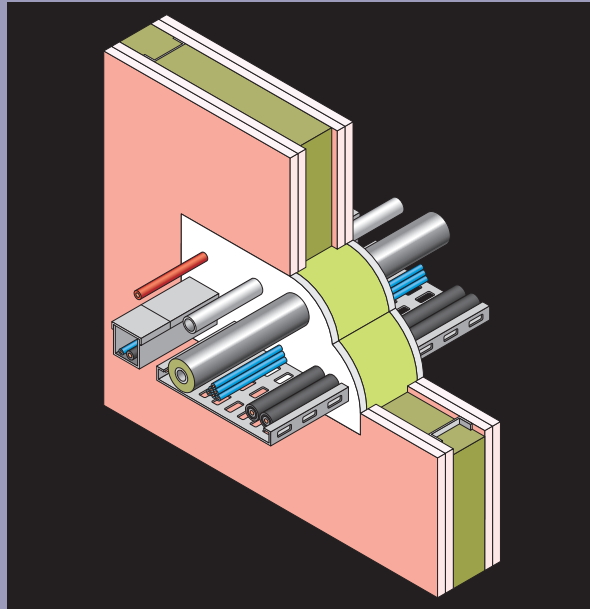

#### Installation

- Ensure contact surfaces are clean, dry and dust free
- Apply between 5°C and 40°C

#### Linear gaps

- For linear gap applications insert backer rod or stone mineral wool, as determined by seal design, into the gap with a friction fit in order to control the required minimum depth of sealant

- Gun the sealant into the gap ensuring that the gap is fully filled and tool the surface smooth within 15 minutes using a dry pallet knife or spatula

#### Service penetrations

- For service penetration seals pack stone mineral wool tightly around and between the services such that the opening is fully filled but leaving sufficient space at each face to apply the required minimum depth of sealant

- Gun the sealant across the exposed faces of the seal ensuring that it is fully filled and tool the surface smooth within 15 minutes using a dry pallet knife or spatula
- Clean tools after use using water

#### Maintenance

No routine maintenance is required although periodic inspection for possible damage is recommended. All penetrations seals which are subsequently modified should be made good using Fireclamp A.

#### Storage

It is recommended to store in dry conditions between 5°C and 25°C.

#### Shelf life

24 months for unopened containers when stored under recommended storage conditions.

#### Health and safety

Please refer to safety data sheet before use.

fireclamp®

Abesco Fire Limited  
Alma Place  
Laurencekirk  
Aberdeenshire  
AB30 1AL  
Scotland  
United Kingdom

TELEPHONE  
**+44 (0) 1561 377 766**  
FAX  
**+44 (0) 1561 378 887**

sales@abesco.net  
www.abesco.net

